



ClaroLux[®]

LANDSCAPE LIGHTING

TL24 Installation Sheet

Venice

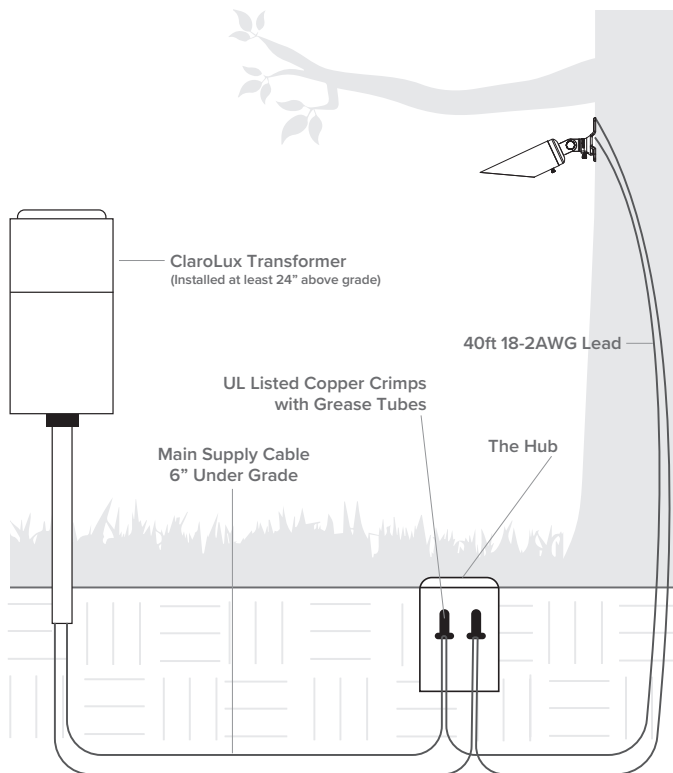

LUMINAIRE MOUNTING

1. To prevent electrical shock, disconnect transformer from electrical supply before installation or service.
2. Secure the slotted brass surface mount in the desired location with stainless steel screws (anchor bolts recommended).
3. Once the surface mount is securely mounted to the surface slide the base of the luminaire into the surface mount. Secure the base of the luminaire by tightening the small thumbscrew on the surface mount.
4. Strip the two leads from luminaire pigtail wire. Using two copper crimps/grease tubes or silicone filled safety connectors, connect the leads from luminaire to main supply cable. *NOTE: Luminaires are supplied with 40' of 18-2 cable pigtail for secure connection to main cable supply. The wire is to be protected by routing in close proximity to luminaire. The wiring should be buried a maximum depth of 6" in order to connect to main supply cable.*
5. Aim luminaire to desired angle. Lock into place by tightening thumbscrew on the adjustable knuckle.

IMPORTANT SAFETY INSTRUCTIONS - THE LIGHTED LAMP IS HOT!

- WARNING:** TO REDUCE THE RISK OF FIRE, OR INJURY TO PERSONS:
- 1) Turn off/unplug and allow to cool before replacing lamp.
 - 2) Lamps get hot quickly! Only contact switch/plug when turning on.
 - 3) Do not touch hot shroud or enclosure.
 - 4) Keep lamp away from material that may burn.
 - 5) Do not touch lamp at any time. Use a soft cloth. Oil from skin may damage lamp.
 - 6) Do not operate luminaire fitting with a missing or damaged cover.

LAMP INSTALLATION & REPLACEMENT:

- CAUTION:** Do not exceed maximum wattage marked on luminaire label.
- 1) To prevent electrical shock, disconnect transformer from electrical supply before service.
 - 2) Remove the lamp from the luminaire.
 - 3) Replace lamp with correct wattage and type marked on fixture label.
- NOTE:** *DO NOT touch lamp with bare hands. Always use soft cloth or the plastic wrapping (if available) from lamp to handle lamp.*

For use with Low Voltage Landscape Lighting Power units. **FOR OUTDOOR USE ONLY.** Amps not to exceed: 25 AMPS; Volts not to exceed: 12 Volts. Max lamp wattage UL 35W & cUL 35W. If using halogen, do not exceed 12V at the luminaire. If using LED, optimal operating range is 10V-14V.

WARNING: Luminaire must be installed in accordance with National Electric Code (NEC) and Local Codes. Failure to do so will void all warranties and may result in serious injury and/or damage to the luminaire.

SAFETY WARNING: Luminaire can become very hot depending on the lamp wattage used. Lens and metal around lamp can become hot enough to blister hands. Particular care should be taken not to locate luminaires where small children can reach them if high wattage lamps are used. **LUMINAIRES ARE NOT TO BE INSTALLED WITH 10 FT. (3.03M) OF A POOL OR SPA. SECONDARY CABLE IS NOT TO BE BURIED MORE THAN 6". WHEN USING MULTIPLE LUMINAIRES, LOAD IS NOT TO EXCEED THE TOTAL WATTS OF TRANSFORMER RATING. DO NOT USE EXTENSION CORDS ON POWER UNITS. LUMINAIRE IS UL LISTED FOR ABOVE GROUND INSTALLATION ONLY.**

NOTE: Use UL rated wire connectors, low voltage power units, cable, and all other components.

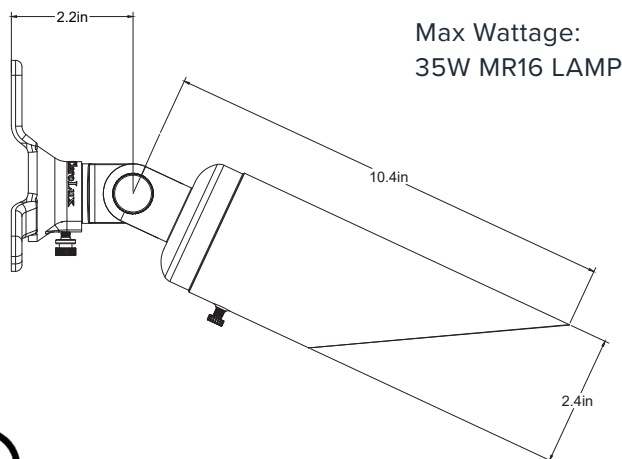

Designed, CNC Machined, Finished and Assembled in America with US and Global Components
 Factory Direct • Professional Grade • Landscape Lighting Fixtures, Supplies and Accessories